



SERIES

High Performance Oil Coolers

- ▶ High Performance Model Series with Louvered Fin Design Provides High Heat Transfer Rates
- ▶ Standard Models with Higher Speed Fans for Compact, Most Economical Selection
- ▶ Low Noise Models with Slower Fan Speeds for Reduced Noise Levels and Lower Fan HP Requirements
- ▶ Competitive Pricing Deliveries From Stock



BULLETIN ACB-2

Standard Models

STANDARD MODELS PERFORMANCE DATA

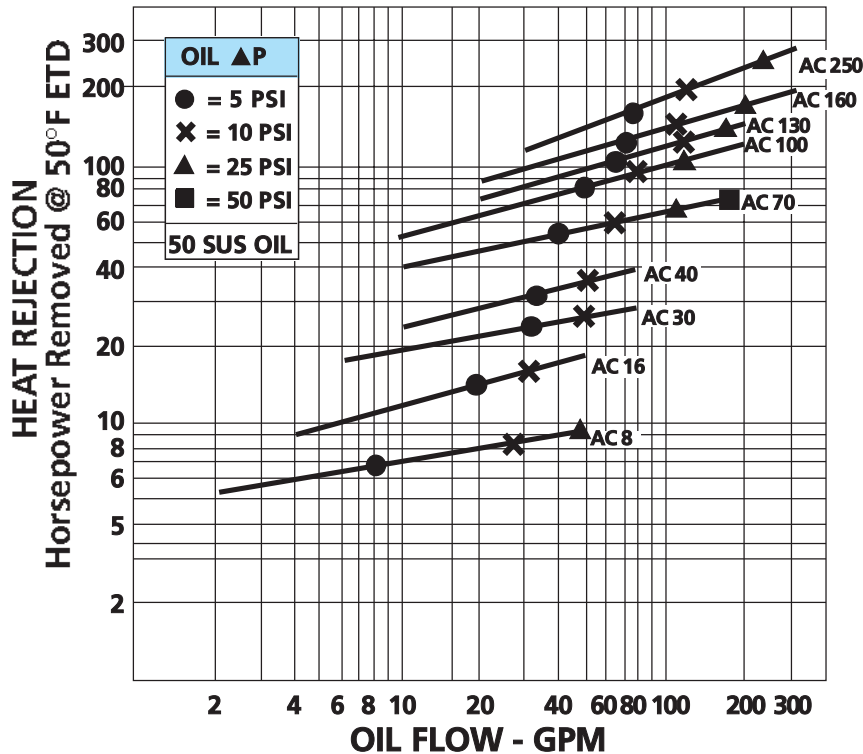

NOISE LEVELS dB A SCALE AT 1 METER	
Model	dB(A)
AC 8	80
AC 16	85
AC 30	85
AC 40	88
AC 70	93
AC 100	94
AC 130	96
AC 160	98
AC 250	101

ELECTRIC MOTOR DATA

Model Size	HP RPM	Motor Frame	SINGLE PHASE			THREE PHASE		
			Voltage	Hz	Full Load Amps 230 V.	Voltage	Hz	Full Load Amps 230V
AC 8	1/3 3250	IEC 63	115/230	60	2.6	208-230/460	60	1.2
						200/220	50	
						380/440	50	
AC 16	1/2 3250	IEC 71	115-208/230	60	3.4	208-230/460	60	2.0
						200/220	50	
						380/440	50	
AC 30	1/2 1725	NEMA 56C	115-208/230	60	4.4	208-230/460	60	3.4
						190/200 208/220	50	
						380/400 416/440	50	
AC 40	1 1725	NEMA 56C	115-208/230	60	6.4	208-230/460	60	6.2
						190/200 208/220	50	
						380/400 416/440	50	
AC 70	2 1725	NEMA 56C	115/230	60	10.0	208-230/480	60	13.4
						190/200 208	50	
						380/400 416	50	
AC 100	5 1725	NEMA 184TC	230	60	23.0	208-230/460	60	19.2
						190/200 208	50	
						380/400 416	50	
AC 130	7.5 1725	NEMA 213TC	Consult Factory	60		208-230/460	60	19.2
						190/200 208	50	
						380/400 416	50	
AC 160	7.5 1725	NEMA 213TC	Consult Factory	60		208-230/460	60	25.0
						190/200 208	50	
						380/400 416	50	
AC 250	10 1725	NEMA 215TC	Consult Factory	60		208-230/460	60	25.0
						190/200 208	50	
						380/400 416	50	

Low Noise Models

LOW NOISE MODELS PERFORMANCE DATA

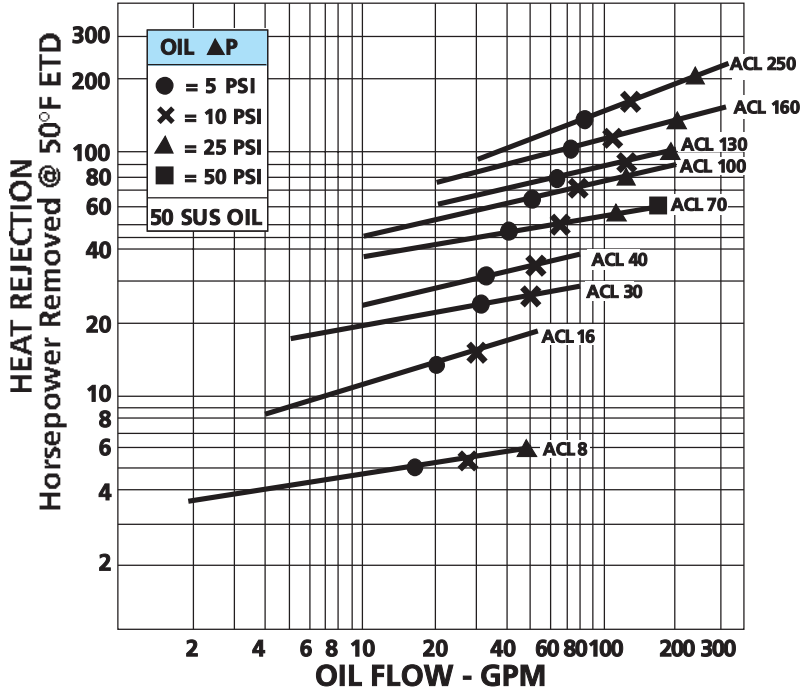

NOISE LEVELS dB A SCALE AT 1 METER	
Model	dB(A)
ACL 8	62
ACL 16	65
ACL 30	72
ACL 40	74
ACL 70	79
ACL 100	80
ACL 130	85
ACL 160	88
ACL 250	90

ELECTRIC MOTOR DATA

Model Size	HP RPM	Motor Frame	SINGLE PHASE			THREE PHASE		
			Voltage	Hz	Full Load Amps 230 V.	Voltage	Hz	Full Load Amps 230V
ACL 8	1/4 1700	IEC 63	Consult Factory			230/460	60	1.0
						220-380/440	50	
ACL 16	1/3 1700	IEC 71	Consult Factory			230/460	60	1.4
						220-380/440	50	
ACL 30	1/2 1140	NEMA 56C	115-208/230	60	4.9	208-230/460	60	2.4
						190/200 208/220	50	
						380/400 416/440	50	
ACL 40	1/2 1140	NEMA 56C	115-208/230	60	4.9	208-230/460	60	2.4
						190/200 208/220	50	
						380/400 416/440	50	
ACL 70	3/4 1140	NEMA 56C	115/208/230	60	5.3	208-230/480	60	3.0
						190/200 208	50	
						380/400 416	50	
ACL 100	1.5 1140	NEMA 56C	Consult Factory			208-230/460	60	5.2
						190/200 208	50	
						380/400 416	50	
ACL 130	2.0 1140	NEMA 184TC	Consult Factory			208-230/460	60	7.6
						190/200 208	50	
						380/400 416	50	
ACL 160	5.0 1140	NEMA 215TC	Consult Factory			230/460	60	16.0
						380/400 416	50	
ACL 250	7.5 1140	NEMA 215TC	Consult Factory			230/460	60	23.0
						380/400 416	50	

Selection Procedures

The performance curves above are based on the following:

- 50 SUS Oil.
- 50°F Entering Temperature Difference (ETD)

If your application conditions are different, use the following selection procedure:

STEP 1. Determine the Heat Load

In most cases you can use 1/3 of the input horsepower.

Example: 30 HP Power Unit = 10 HP Heat Load

STEP 2. Determine the Actual ETD Desired

Entering OIL Temperature — Entering AIR Temperature = ETD

The entering oil temperature is the highest desired oil temperature. The entering air temperature is the highest anticipated ambient air temperature, plus any pre-heating of the air prior to its entering the cooler.

STEP 3. Calculate the Adjusted BTU/hr for Selection

$$\frac{\text{Horsepower}}{\text{Heat Load}} \times \frac{50}{\text{Desired ETD}} = \text{Horsepower For Use With Selection Chart}$$

OIL PRESSURE DROP CORRECTION

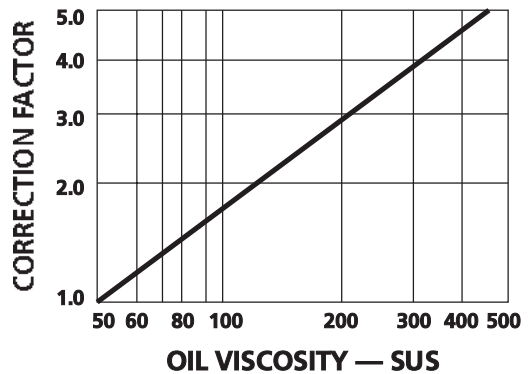

STEP 4. Select The Model From The Curves

Read up from the GPM to the required heat rejection. Select any model on, or above this point.

STEP 5. Calculate Oil Pressure Drop

Find the oil pressure drop correction factor and multiply it by the oil pressure drop found on the performance curve.

Specifications

RATINGS:

Maximum Working Pressure250 PSI

Maximum Working Temperature.....250 °F

MATERIALS:

Cooler.....Alumium

Fan Blade.....Polypropylene Blades
Aluminum Hub

Shroud.....Powder Painted Steel

Mounting Brackets.....Powder Painted Steel

Fan Guard.....Zinc Plated Steel

Electric motors are totally enclosed, and are not thermally protected.

Actual ratings vary with motor brand. Check motor nameplate for actual ratings.

Motor RPM is reduced by 1/6 for 50 Hz service.

Dimensions

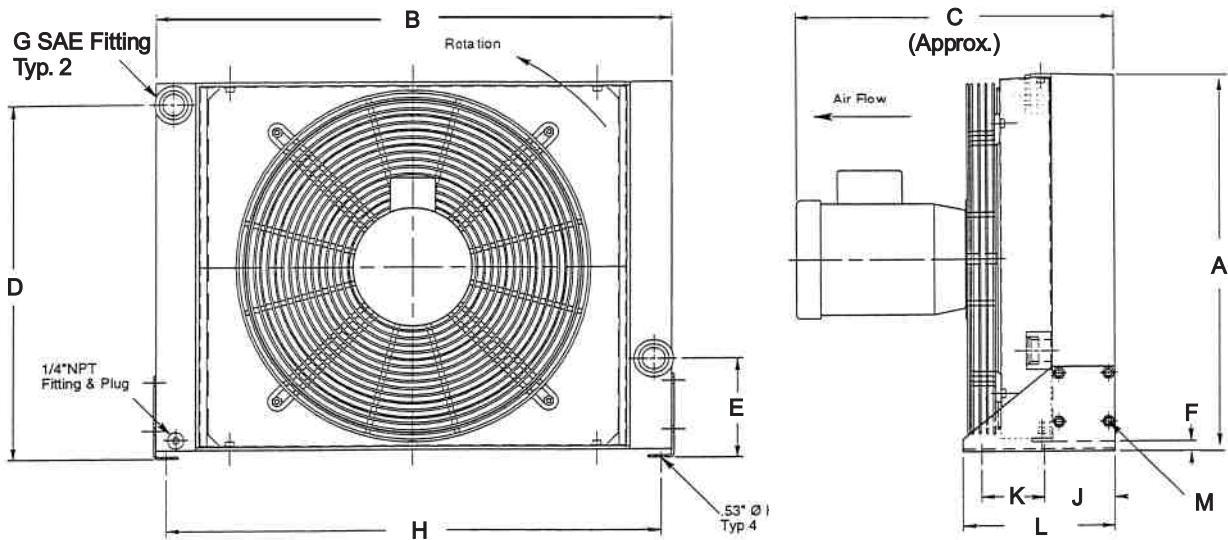

MODEL	A	B	C (Approx.)	D	E	F	G	H	J	K	L	M	Approx. Weights	
													Net	Shipping
AC 8	12.44	15.75	14.72	11.30	3.27	0.55	#16 SAE 1 1/4-12 UN-2B	14.53	3.07	3.50	7.36	M8x10 Bolt (4 PL)	35	45
AC 16	16.26	19.88	15.59	15.08	3.35	0.59		18.66					45	55
AC 30	20.59	26.38	17.76	19.29	6.02	0.59	#20 SAE 1 1/2-12 UN-2B	25.20	4.17	3.74	9.02	M10x20 Bolt (8 PL)	90	125
AC 40	22.44	30.32	18.74	21.18				29.09					125	163
AC 70	28.27	37.01	22.60	20.47	9.92	2.09	2" SAE 4-Bolt FLANGE	37.48	5.39	7.87	15.47	M12x20 Bolt (8 PL)	195	240
AC 100	37.40	40.95	24.76	29.69	9.02	0.59		41.42					350	405
AC 130	37.52	42.91	29.84	35.52	9.13	0.59		43.49					365	420
AC 160	44.09	48.82	30.28	34.72	11.02	0.65		49.29					480	545
AC 250	57.64	52.76	33.82	43.62	17.56	2.04	3" SAE 4-Bolt FLANGE	50.55	7.80	10.00	20.00	3/4 x 1 1/2 Bolt (8 PL)	600	688

- Dimensions are in inches.
- We reserve the right to make reasonable design changes without notice.
- Weights are in pounds.

Ordering Information



AC SERIES
Standard

ACL SERIES
Low Noise



MODEL SIZE
SELECTED



MOTOR DATA
0=NO MOTOR
C=CORE ONLY
1= SINGLE PHASE
3=THREE PHASE
575=575 VOLT



CUSTOM FEATURE CODE
R=REVERSED AIR FLOW
AD=SAE TO NPT ADAPTORS INSTALLED
H=HERESITE COATING/CORE ASSEMBLY
CRN=CANADIAN REGISTRY, 250 PSI
CRS=CANADIAN REGISTRY, 150 PSI