

SERIES



MRS - LMP

Return/Suction Filter

In-Line/Return/Suction Filter

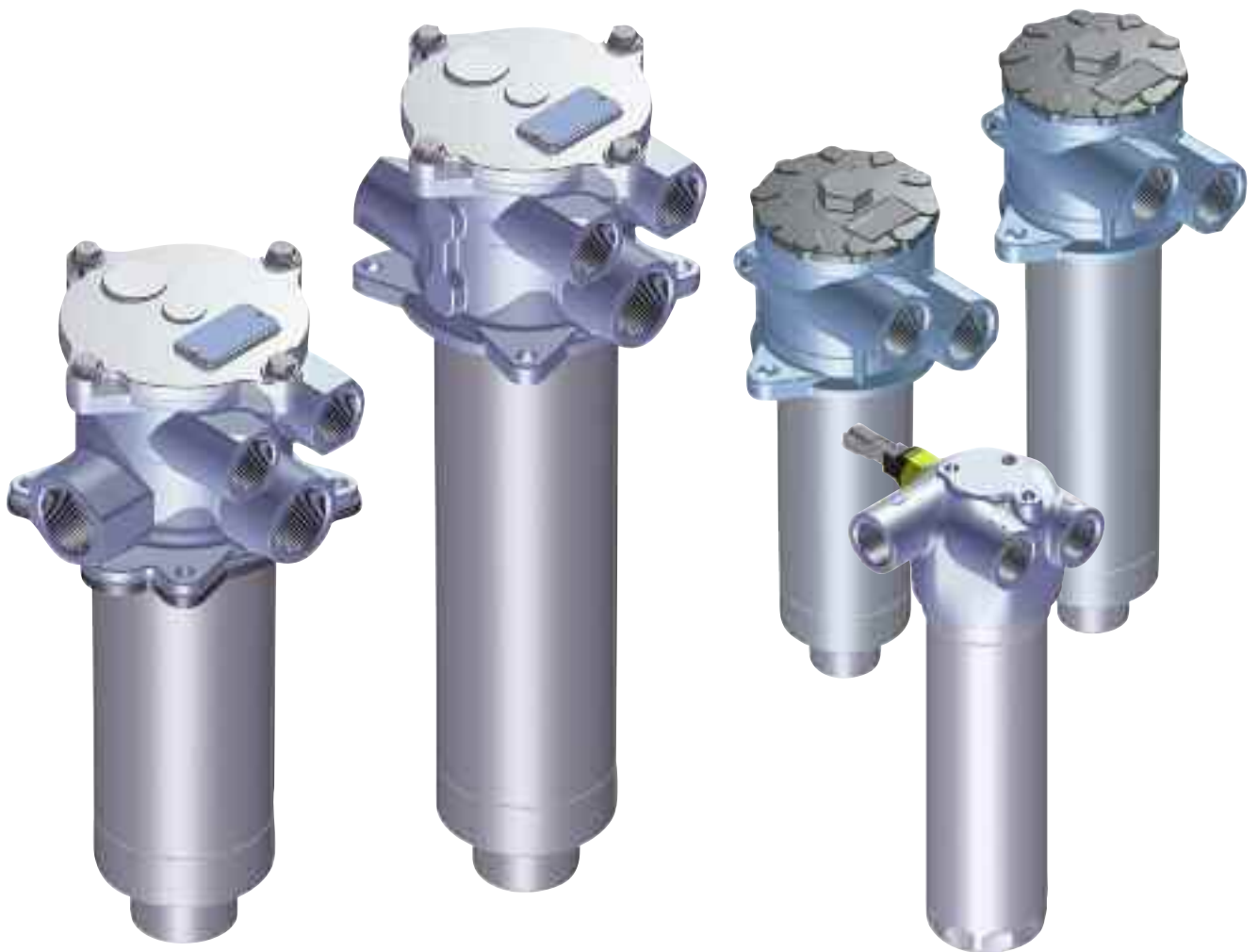

Maximum flow to 300 l/min



Technical data

MRS 116 - 165 - 166

Filter housing (Materials)

- Head: Aluminium
- Cover: Nylon (MRS 116)
Aluminium (MRS 165-166)
- Bowl: Nylon

LMP 124

Filter housing (Materials)

- Head: Aluminium
- Housing: Steel Cataphoresis Painting
- Bypass valve: Brass - Aluminium

MRS 116 - 165 - 166 - Pressure

- Working pressure: 10 bar

LMP 124 - Pressure

- Working pressure: 80 bar (8 MPa)
- Test pressure: 120 bar (12 MPa)
- Burst pressure: 380 bar (38 MPa)
- Pulse pressure fatigue test: 1.000.000 cycles with pressure from 0 to 80 bar (8 MPa)

Temperature

- From -25 °C to +110 °C

Δp Elements

- RS: 10 bar (MRS)
- CU: 20 bar (LMP)
- Oil flow from exterior to interior.

Seals

- Standard NBR series A
- Optional FPM series V

Weights (kg)

Length	1	2	3	4
• MRS 116	1,30	1,40	-	-
• MRS 165	3,40	3,80	4,10	-
• MRS 166	3,40	3,80	4,10	-
• LMP 124	1,70	1,90	2,20	2,70

Volumes (dm³)

Length	1	2	3	4
• MRS 116	0,80	1,00	-	-
• MRS 165	2,00	2,60	3,00	-
• MRS 166	2,00	2,60	3,00	-
• LMP 124	0,75	0,81	1,11	1,53

MRS - LMP

Compatibility (to ISO 2943)

- Mineral oils
- Synthetic fluids
- Biodegradable fluids

Filter housings Δp pressure drop

The curves are plotted utilising mineral oil with density of 0.86 kg/dm³ to ISO 3968.

Δp varies proportionally with density.

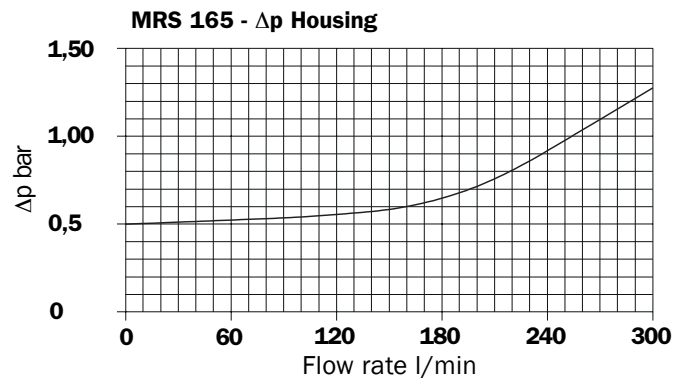
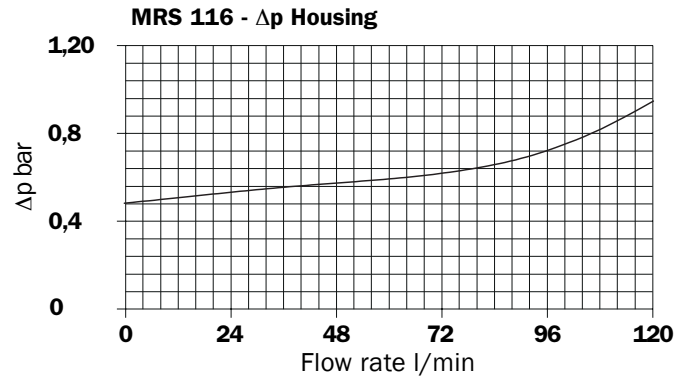

Valves

Bypass valve pressure drop

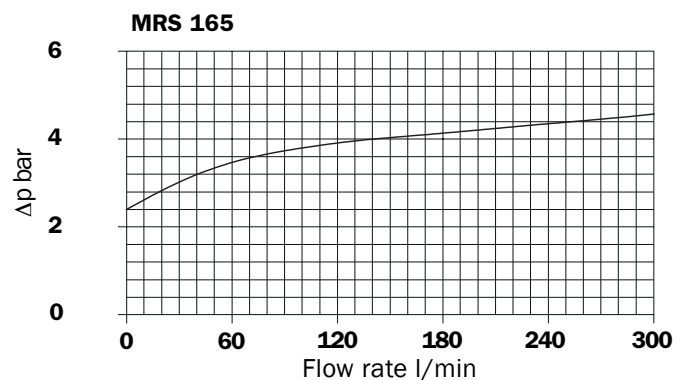
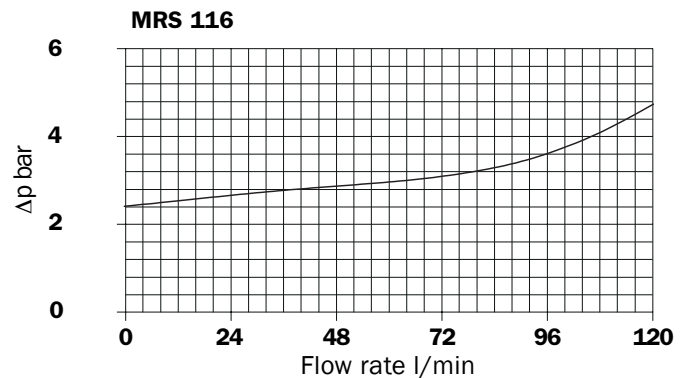

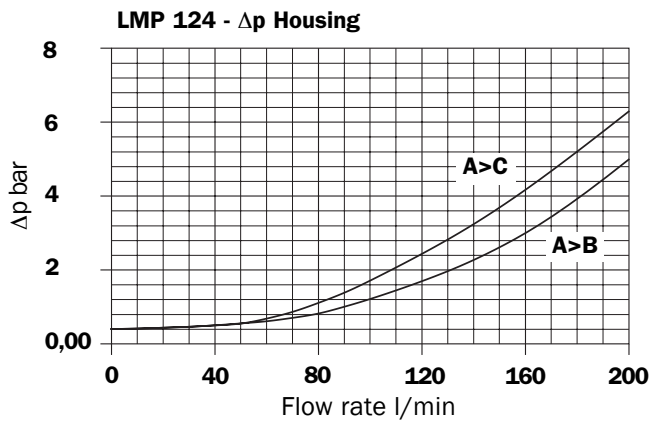

Valves

Bypass valve pressure drop

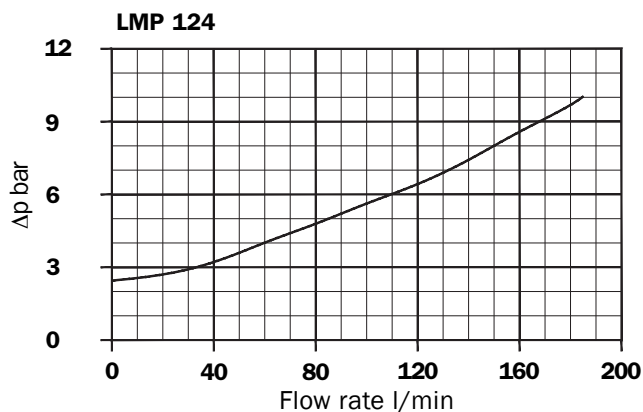

Multiplication factor “Y” for definition of the pressure drop of filter elements.

Reference viscosity 30 mm²/s

Filter Element	Absolute Filtration			
	N Series			
Type	A 1 0	A 1 6	A 2 5	
CU 110	1	8,754	8,142	5,875
	2	6,111	6,024	4,155
	3	5,066	4,066	2,397
	4	2,798	2,358	1,142
RS 116	1	5,12	4,33	3,85
	2	2,22	1,87	1,22
RS 165	1	2,06	1,75	1,46
	2	1,24	1,05	0,96
	3	0,94	0,86	0,61

Sizing data for single cartridge, head at top

Δp Tot.

Δpc Filter housing

Δpe Filter element

Y Multiplication factor (see below)

Q l/min = flow rate

V1 = reference viscosity 30 mm²/s (cSt)

V2 = operating viscosity in mm²/s (cSt)

Δp Tot. = Δpc + Δpe

Δpe = Y : 1000 x Q x (V2/V1)

Calculation example with HLP Mineral Oil Variation in viscosity

Data:

Filter with in-line connections

Pressure = 6 bar

Flow rate = 200 l/min

Viscosity = 46 mm²/s (cSt)

Density = 0,86 Kg/dm³

Filtration = 10 μ absolute

With bypass valve

Practical example

Δpe Filter housing

Q = 200 l/min

V₂ = 46 mm²/s (cSt)

Pmax = 6 bar

Filtration = 10 μ absolute

Δp Tot. max = **0,4 bar** (max. recommended value)

Δpe = (1,24 : 1000) x 200 x (46/30) = **0,37 bar**

Δpc Filter housing

Q tot = 200 l/min

Q1 to the tank = 150 l/min

Q2 to the pump = 50 l/min

Filter type - MRS 165 (see below housings pressure drop)

Δp Tot. max 1 - 1,6 bar = Δpc + Δpe

Δp Tot. = **0,59 (Q1) + 0,37 = 0,96 bar**

Sized filter type:

MRS 165 2 F A G1 0 A10 S P01

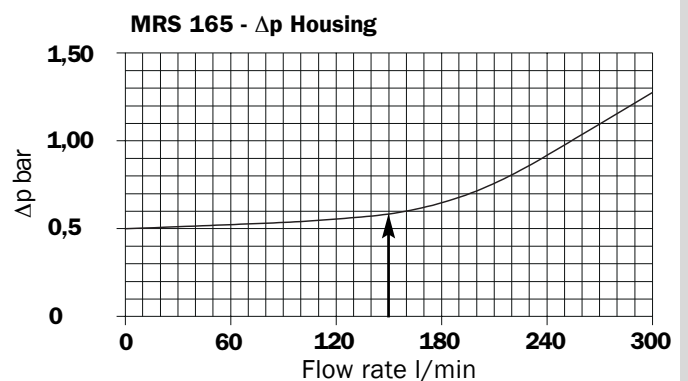

Hydraulic schemes

LEGEND

- 1 - Filter element
- 2 - Back-Pressure valve: opening pressure 0,5 bar \pm 10%
- 3 - Bypass valve: opening pressure 2,5 bar \pm 10%
- 4 - Depressurization valve
- 5 - Anti-Cavitation valve
- 6 - Safety filter element (wire mesh 60 μ m)

MRS 116

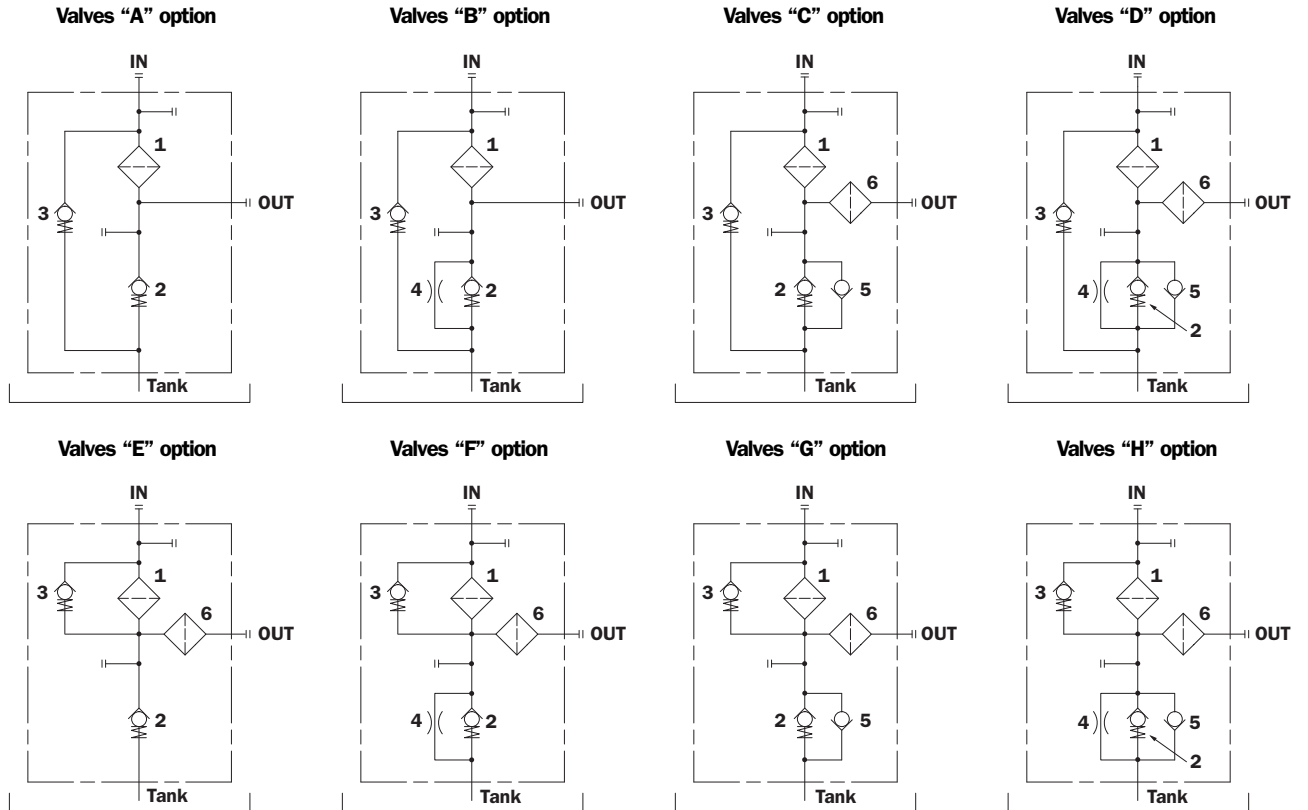

MRS 165 - 166

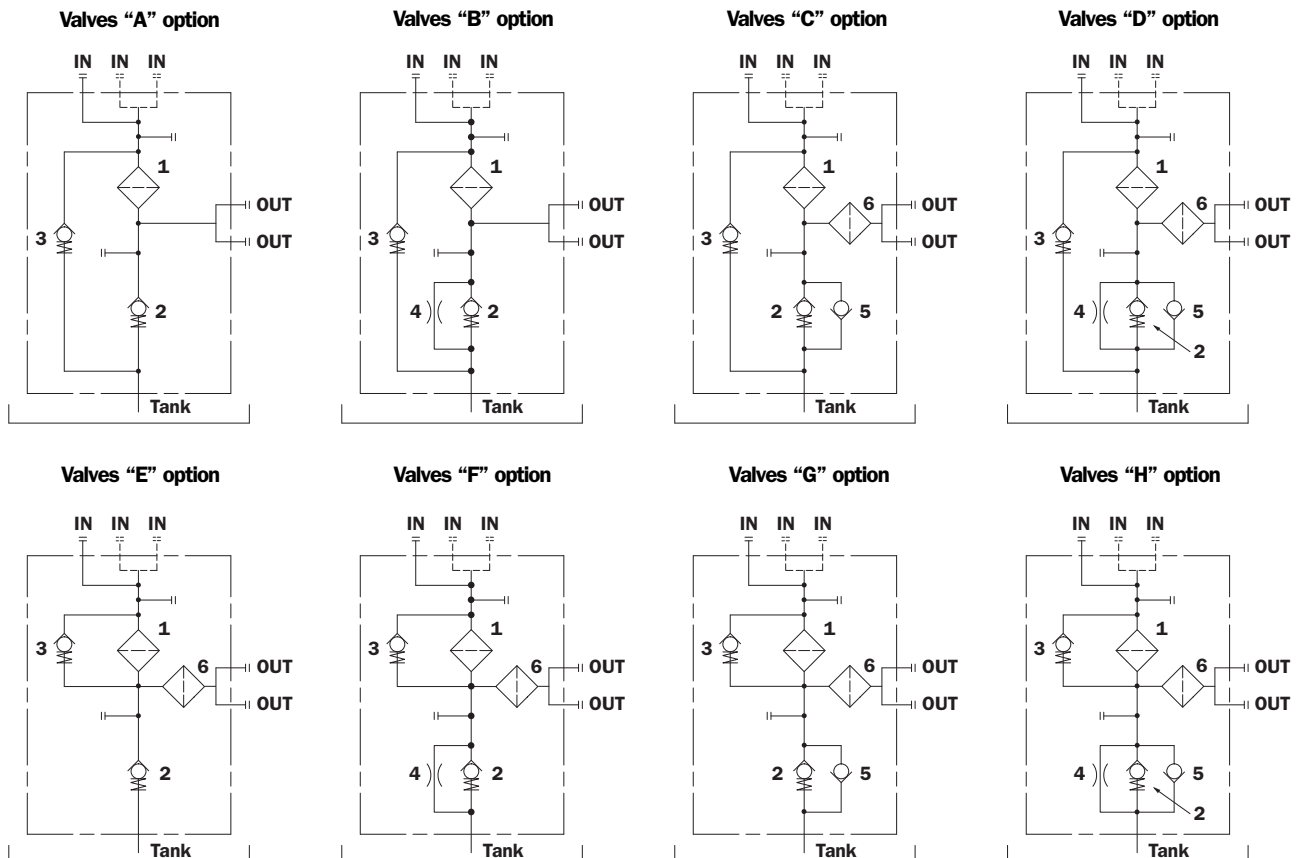

Port configuration

MRS 116

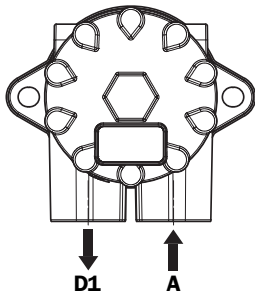

MRS 165

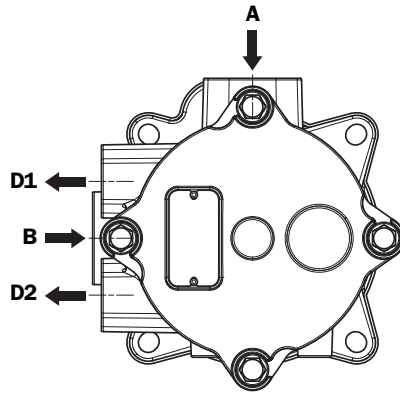

MRS 166

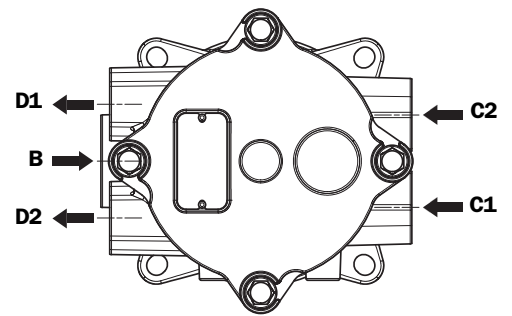

Thread connections

Code	A (IN)	B (IN)	C1 (IN)	C2 (IN)	D1 (OUT)	D2 (OUT)	T (Indicator port)
MRS 116 x x G1 0 xxx x P01	G 3/4"	-	-	-	G 3/4"	-	G 1/8"
MRS 116 x x G2 0 xxx x P01	G 1"	-	-	-	G 1"	-	G 1/8"
MRS 116 x x G3 0 xxx x P01	3/4" NPT	-	-	-	3/4" NPT	-	1/8" NPT
MRS 116 x x G4 0 xxx x P01	1" NPT	-	-	-	1" NPT	-	1/8" NPT
MRS 116 x x G5 0 xxx x P01	SAE 12	-	-	-	SAE 12	-	1/8" NPT
MRS 116 x x G6 0 xxx x P01	SAE 16	-	-	-	SAE 16	-	1/8" NPT
MRS 165 x x G1 0 xxx x P01	G 1 1/4"	-	-	-	G 1"	G 1"	G 1/8"
MRS 165 x x G2 0 xxx x P01	1 1/4" NPT	-	-	-	1" NPT	1" NPT	1/8" NPT
MRS 165 x x G3 0 xxx x P01	SAE 20	-	-	-	SAE 16	SAE 16	1/8" NPT
MRS 165 x x G1 1 xxx x P01	G 1 1/4"	G 1 1/4"	-	-	G 1"	G 1"	G 1/8"
MRS 165 x x G2 1 xxx x P01	1 1/4" NPT	1 1/4" NPT	-	-	1" NPT	1" NPT	1/8" NPT
MRS 165 x x G3 1 xxx x P01	SAE 20	SAE 20	-	-	SAE 16	SAE 16	1/8" NPT
MRS 166 x x G1 1 xxx x P01	-	G 1 1/4"	G 1"	G 1"	G 1"	G 1"	G 1/8"
MRS 166 x x G2 1 xxx x P01	-	1 1/4" NPT	1" NPT	1" NPT	1" NPT	1" NPT	1/8" NPT
MRS 166 x x G3 1 xxx x P01	-	SAE 20	SAE 16	SAE 16	SAE 16	SAE 16	1/8" NPT

Hydraulic schemes

LMP 124

Style C - D - E - F



**Style C
LMP 124**

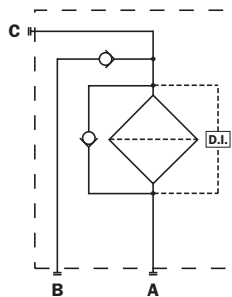

**Style E
LMP 124**

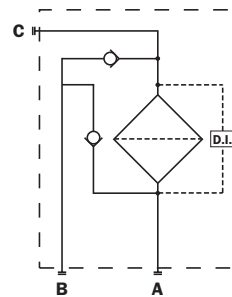

**Style G
LMP 124**

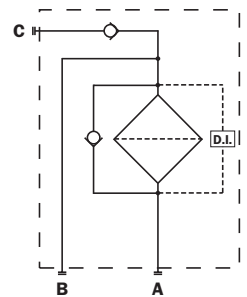

LMP 124

Style G - H

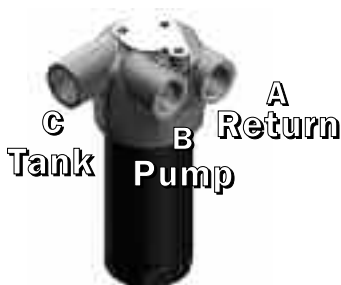

**Style D
LMP 124**

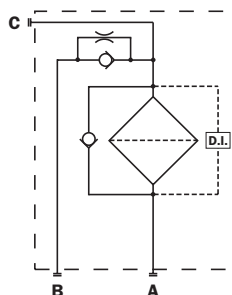

**Style F
LMP 124**

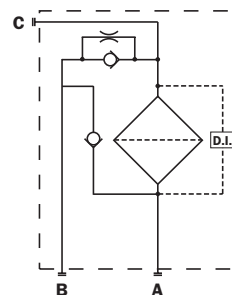

**Style H
LMP 124**

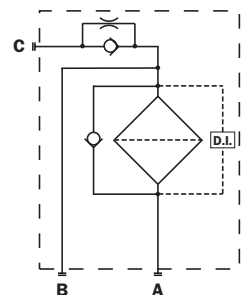

Dimensions

MRS 116

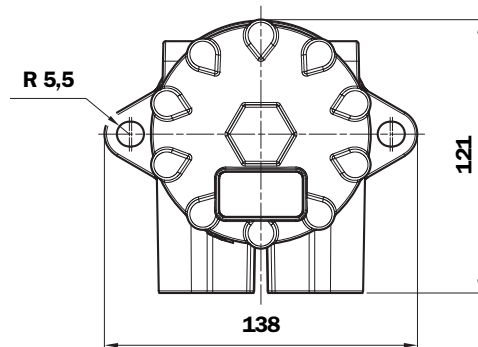
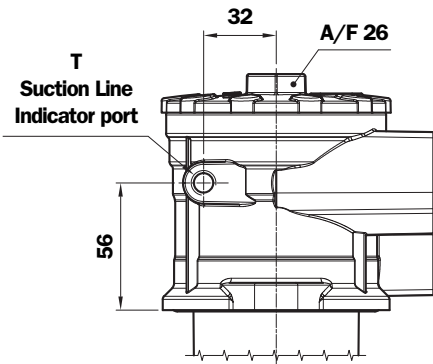
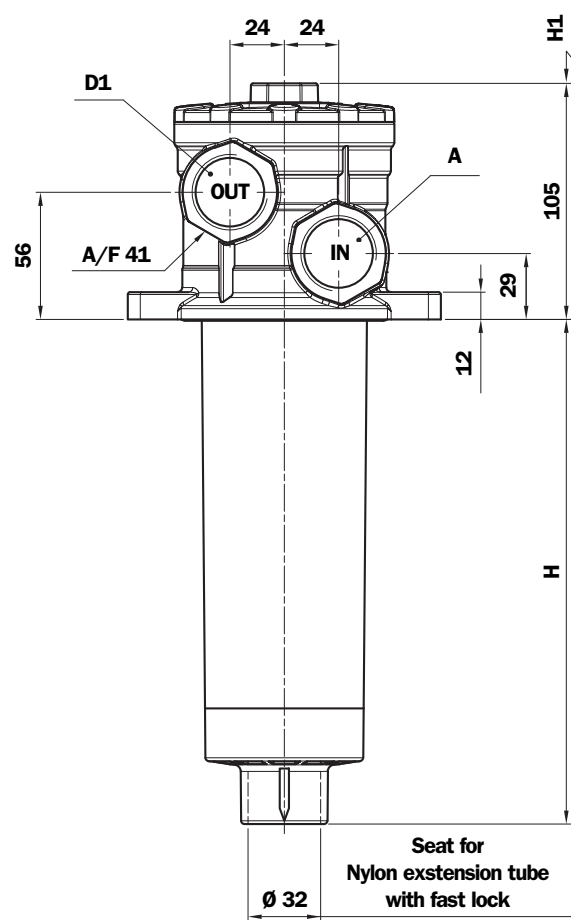
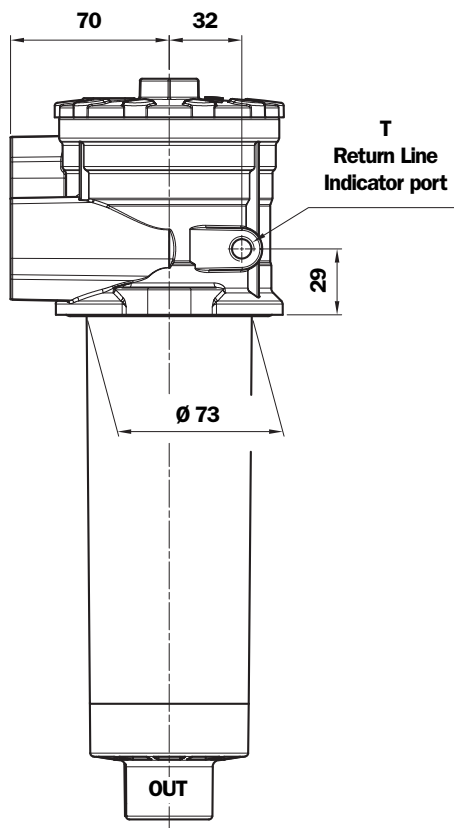

Holes on the tank

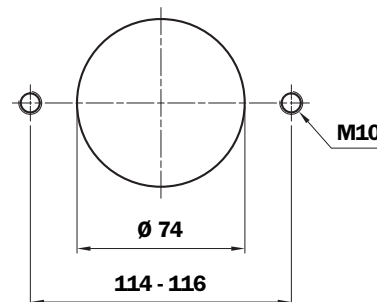

MRS 116

Filter Length	H mm	H1 mm
1	203	240
2	263	300

See page 5 to choose thread connections

MRS 165

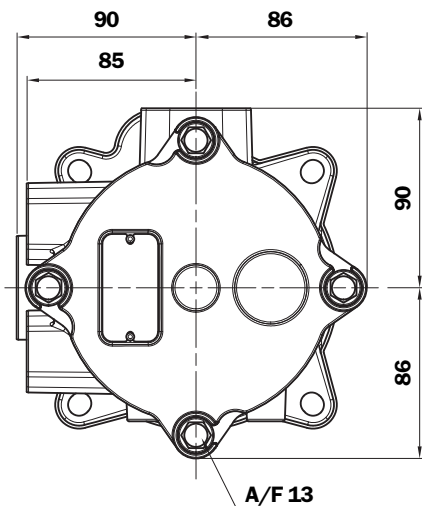
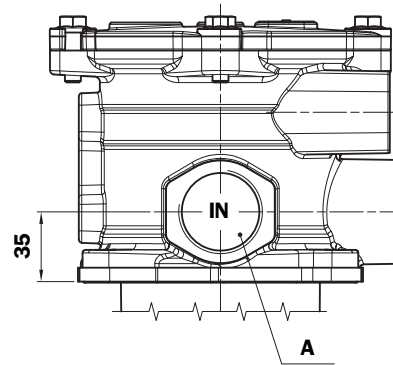
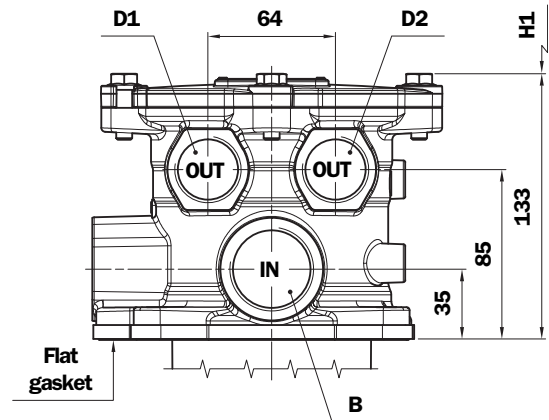
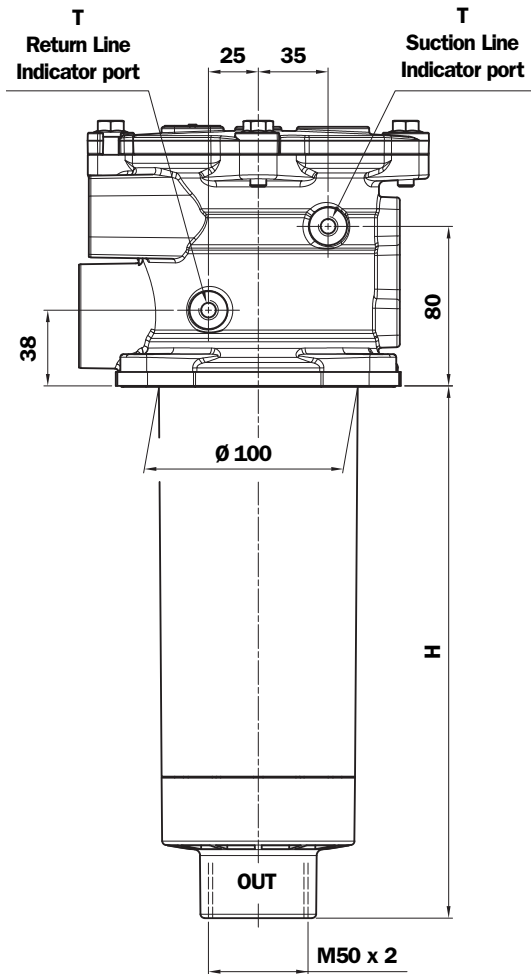

Holes on the tank

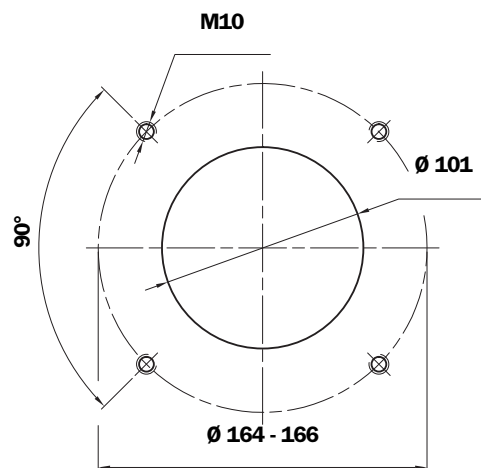

MRS 165

Filter Length	H mm	H1 mm
1	267	320
2	375	430
3	442	500

See page 5 to choose thread connections

MRS 166

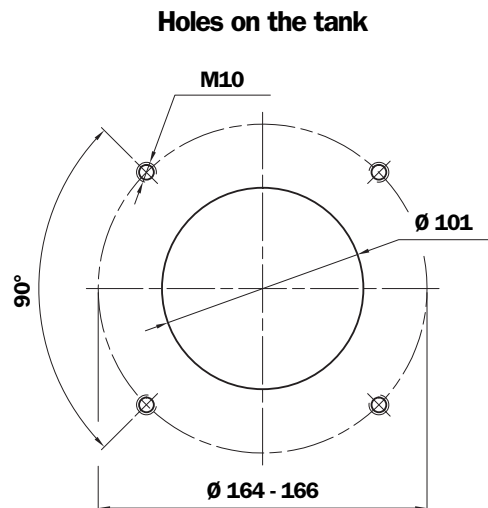
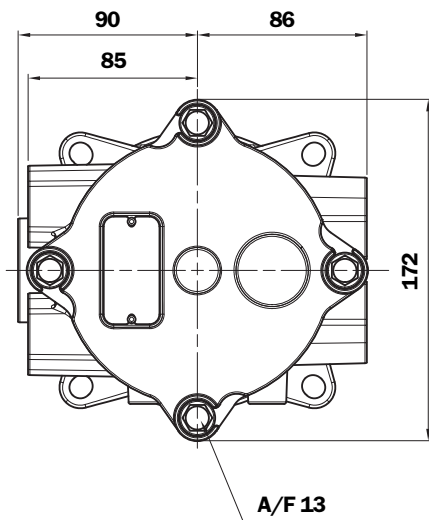
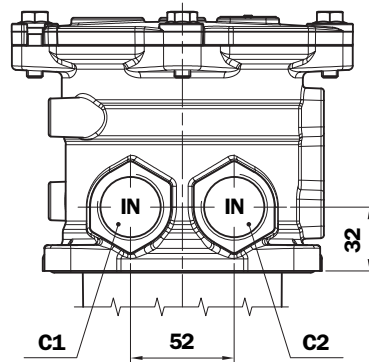
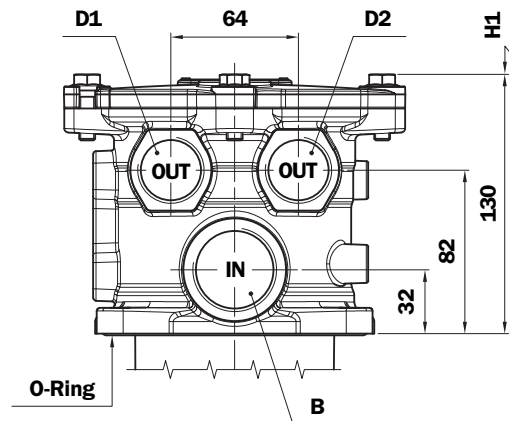
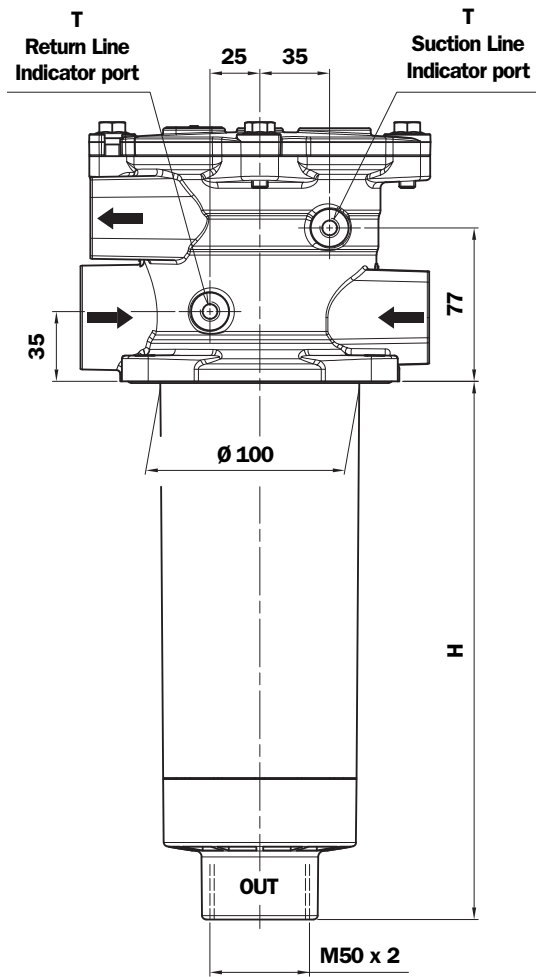

MRS 166

Filter Length	H mm	H1 mm
1	270	320
2	378	430
3	445	500

See page 5 to choose thread connections

LMP 124

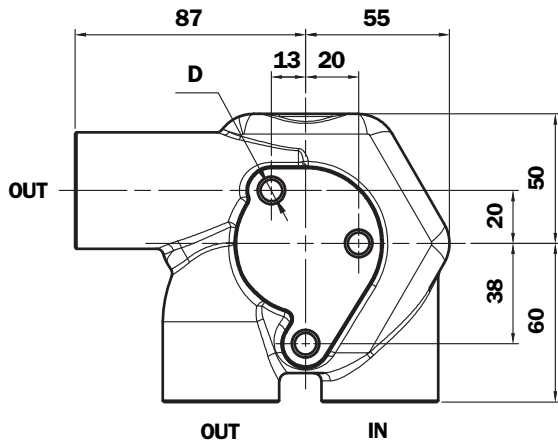
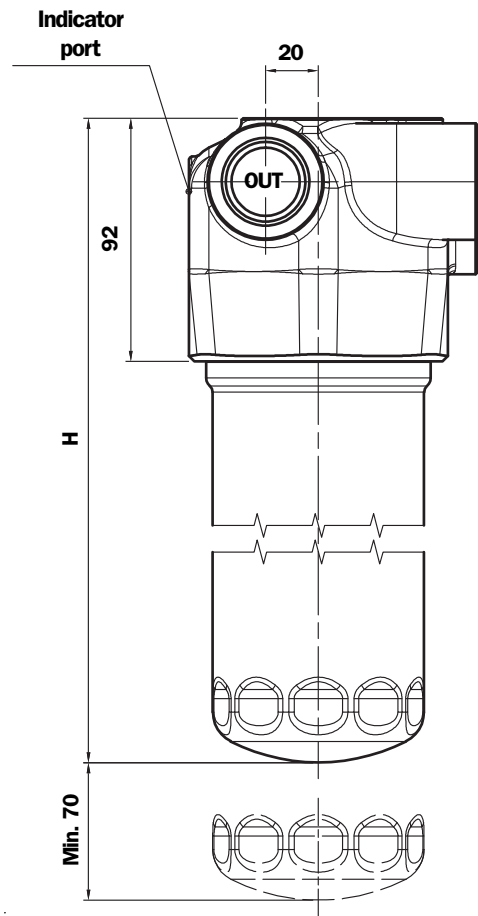
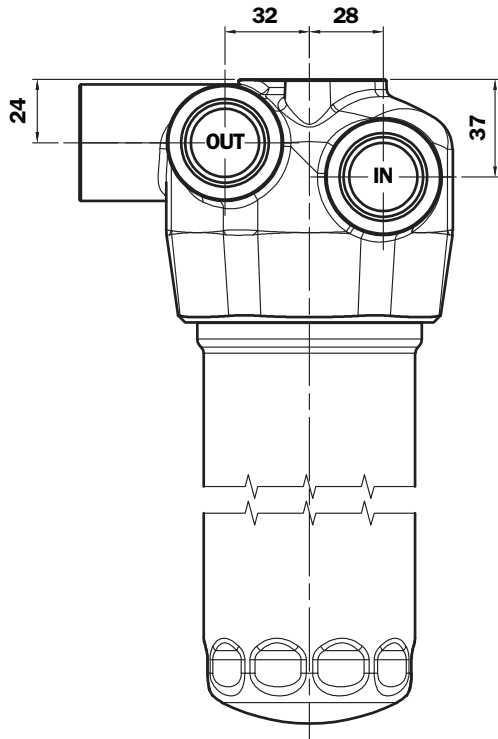

LMP 124

Length Filter	H mm
1	182
2	215
3	265
4	365

Type	Connection IN - OUT	Fixing holes D
B	G 1"	M10 x depth 12 mm
F	SAE 16	3/8" UNC x depth 12 mm

Ordering information MRS 116 - 165 - 166

Filter assembly

MRS

	1	2	3	4a	5	6	7	8	9
Example 1: MRS	116	1	A	A	G1	0	A16	S	P01
Example 2: MRS	165	2	C	B	G3	0	A10	S	P01
Example 3: MRS	166	3	G	A	G2	1	A25	S	P01

Filter element

RS

	1	2	7	4b	9
Example 1: RS	116	1	A16	A	P01
Example 2: RS	165	2	A10	A	P01
Example 3: RS	165	3	A25	A	P01

1 - Size

Filter	Filter element
116	116
165	165
166	165

2 - Filter length

116	1	2	
165	1	2	3
166	1	2	3

3 - Valves option

A	E	See page 4 for "Hydraulic schemes"
B	F	
C	G	
D	H	

4 - Seals

4a - Filter assembly

A	NBR - O-Ring on head
B	NBR - Flat gasket on head
V	FPM - O-Ring on head
D	FPM - Flat gasket on head

4b - Filter element

A	NBR
V	FPM

5 - Standard connections

MRS 116		See page 5 to choose threaded connections
G1	G4	
G2	G5	
G3	G6	

MRS 165 - 166

G1	See page 5 to choose threaded connections
G2	
G3	

6 - Additional IN connections

0	(Not available for MRS 166)
1	(Not available for MRS 116)

See page 5 to choose threaded connections

7 - Filter element

A10	Inorganic microfibre 10 μ	Absolute filtration Inorganic Microfibre $\beta_x(c) \geq 1000$
A16	Inorganic microfibre 16 μ	
A25	Inorganic microfibre 25 μ	

8 - Style

S	Standard
B	Suitable for tank side-wall mounting applications (only for valves option A - B - E - F)

9 - Option

P01	MP Filtri standard
Pxx	On request

www.mpfiltri.com

MP Filtri - The filter functions as described in this bulletin are valid exclusively for original MP Filtri filter elements and replacement parts. All rights reserved

The data in this publication are purely guideline. MP Filtri reserves the right to make changes to the models described herein at any time it deems fit in relation to technical or commercial requirements. The colours of the products shown on the cover are purely guideline. Copyright. All rights reserved.

Ordering information LMP 124

Filter assembly **LMP**

Example: LMP

1	2	3	4	5	6	7	8	9
<input type="text"/>	<input type="text"/>	<input type="text"/>	<input type="text"/>	<input type="text"/>	<input type="text"/>	<input type="text"/>	<input type="text"/>	<input type="text"/>
124	2	C	A	B	2	A10	N	P01

Filter element **CU110**

Example: CU110

2	7	4	8	9
<input type="text"/>	<input type="text"/>	<input type="text"/>	<input type="text"/>	<input type="text"/>
2	A10	A	N	P01

1 - Size

Filter

124

Filter element

110

2 - Filter length

-
-
-
-

3 - Valves option

-
-
-
-
-
-

See page 5
for "Hydraulic schemes"

4 - Filter seals

- NBR
- FPM
- NBR (Compatible with fluid HFA, HFB, HFC)
- On request

5 - Connection

LMP 124

Type	Connection A - B - C
B	G 1"
F	SAE 16

6 - Indicator port

- No
- Port G 1/8" switch
For pressure switch
- Port G 1/4"
For pressure switch
- Differential indicator port

7 - Filter element

- Inorganic microfibre 10 μ
 - Inorganic microfibre 16 μ
 - Inorganic microfibre 25 μ
- Absolute filtration
 $\beta_x(c) \geq 1000$

8 - Max filter element differential pressure

- Δp 20 bar

9 - Option

- MP Filtri standard
- On request

www.mpfiltri.com

MP Filtri - The filter functions as described in this bulletin are valid exclusively for original MP Filtri filter elements and replacement parts. All rights reserved

The data in this publication are purely guideline. MP Filtri reserves the right to make changes to the models described herein at any time it deems fit in relation to technical or commercial requirements. The colours of the products shown on the cover are purely guideline. Copyright. All rights reserved.

Barometric indicators

BVA

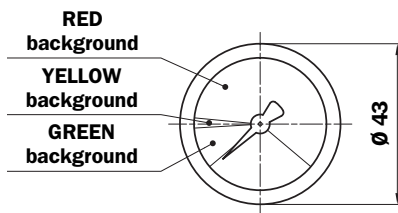

R 1/8" - EN 10226

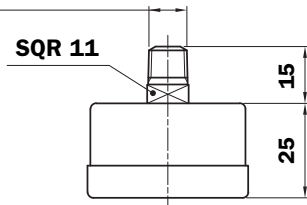

Ordering code: **BLA25HA71P01**

Pressure setting: 2,5 bar ±10%

Axial Pressure Gauge

Materials:

- Case: Painted Steel
- Window: Clear plastic
- Dial: Painted Steel
- Pointer: Painted Aluminium
- Pressure connection: Brass
- Pressure element: Bourdon tub cu-alloy soft soldered

Technical data:

- Indicator type: Axial pressure gauge
- Max working pressure: Static: 7 bar
Fluctuating: 6 bar
Short time: 10 bar
- Working temperature: From -40°C to +60°C
- Compatibility with fluids: Mineral oils, Synthetic fluids
HFA, HFB, HFC fluids in according to ISO 2943
- Accuracy class: cl. 2.5
- Protection degree: IP 31 in according to EN 60529

HYDRAULIC SYMBOL



DYED RANGE

- BVA25P01
- GREEN BACKGROUND (from 0 to 2,5 bar)
Clean filter element
- YELLOW BACKGROUND (from 2,5 to 3 bar)
Warning
- RED BACKGROUND (from 3 to 10 bar)
Bypass

BEA

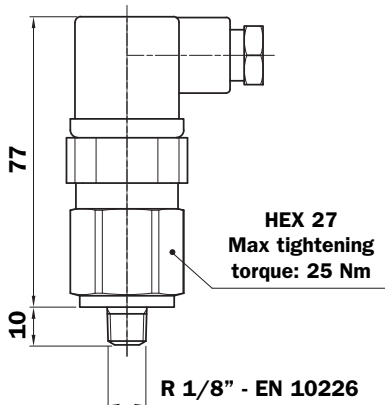

Ordering code: **BEA25HA50P01**

Pressure setting: 2,5 bar ±10%

Electrical Pressure Indicator

Materials:

- Body: Brass
- Internal parts: Brass - Nylon
- Seals: NBR

Technical data:

- Indicator type: Electrical pressure indicator
- Max working pressure: 40 bar
- Proof pressure: 60 bar
- Working temperature: From -25°C to +80°C
- Compatibility with fluids: Mineral oils, Synthetic fluids
HFA, HFB, HFC fluids in according to ISO 2943

Electrical data:

- Resistive load: 5 A / 14 VDC
4 A / 30 VDC
5 A / 125 VAC
5 A / 250 VAC
- Electrical connections: 50 - EN 175301-803
- Protection degree: IP 65 in according to EN 60529
- Available ATEX product: II 1GD Ex ia IIC Tx Ex ia IIIC Tx °C X

HYDRAULIC SYMBOL

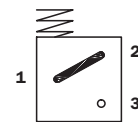

ELECTRICAL SYMBOL

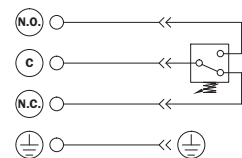

BET

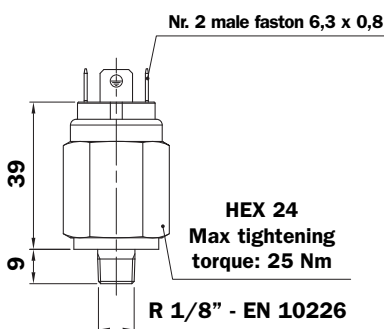

Ordering code: **BET25HF05P01**

Pressure setting: 2,5 bar ±10%

Electrical Pressure Indicator

Materials:

- Body: Brass
- Internal parts: Brass - Nylon
- Seals: HNBR

Technical data:

- Indicator type: Electrical pressure indicator with thermostat
- Thermostat setting: 30°C
- Max working pressure: 10 bar
- Proof pressure: 15 bar
- Working temperature: From -25°C to +100°C
- Compatibility with fluids: Mineral oils, Synthetic fluids
HFA, HFB, HFC fluids in according to ISO 2943

Electrical data:

- Resistive load: 0,5 A / 48 VDC
- Electrical connections: Faston 6,3 x 0,8

HYDRAULIC SYMBOL

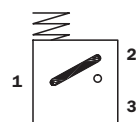

ELECTRICAL SYMBOL

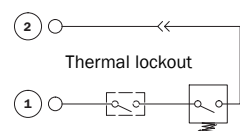

VVA

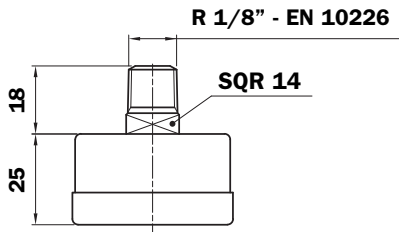
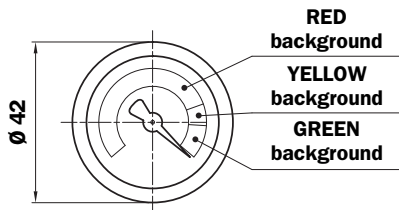

Ordering code: **VVB16P01**
 Connection: R 1/8" EN 10226

Axial Vacuum Gauge

Materials:

- Case: Painted Steel
- Window: Clear plastic
- Dial: Painted Steel
- Pointer: Painted Aluminium
- Pressure connection: Brass
- Pressure element: Bourdon tub Cu-alloy soft soldered

Technical data:

- Indicator type: Axial vacuum gauge
- Max working pressure: Static: 7 bar
Fluctuating: 6 bar
Short time: 10 bar
- Working temperature: From -40 °C to +60 °C
- Compatibility with fluids: Mineral oils, Synthetic fluids
HFA, HFB, HFC fluids in according to ISO 2943
- Accuracy class: cl. 2.5
- Protection degree: IP 31 in according to EN 60529

HYDRAULIC SYMBOL



GRADUATED DISPLAY

GREEN BACKGROUND
 (from 0 to -12 cmHg)
 Clean filter element

YELLOW BACKGROUND
 (from -12 to -18 cmHg)
 Warning

GREEN BACKGROUND
 (from -18 to -76 cmHg)
 Bypass

VEA - VEB

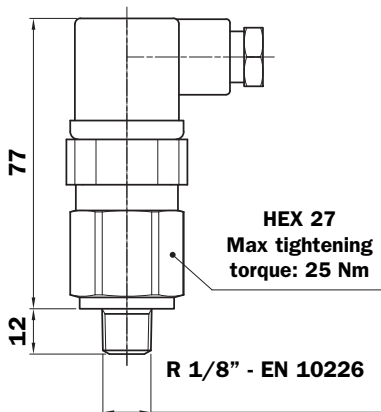

Ordering code: **VEB21AA50P01**
 Connection: R 1/8" EN 10226

Electrical Vacuum Indicator

Materials:

- Body: Brass
- Internal parts: Brass - Nylon
- Seals: NBR

Technical data:

- Indicator type: Electrical vacuum indicator
- Setting pressure: -0,21 bar ±10%
- Max working pressure: 10 bar
- Proof pressure: 15 bar
- Working temperature: From -25 °C to +80 °C
- Compatibility with fluids: Mineral oils, Synthetic fluids
HFA, HFB, HFC fluids in according to ISO 2943

Electrical data:

- Resistive load: 5 A / 14 VDC
4 A / 30 VDC
5 A / 125 VAC
5 A / 250 VAC
- Electrical connections: 50 - EN 175301-803
- Protection degree: IP 65 in according to EN 60529
- Available Atex product II 1GD Ex ia IIC Tx Ex ia IIIC Tx °C X

HYDRAULIC SYMBOL

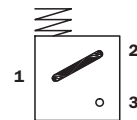

ELECTRICAL SYMBOL

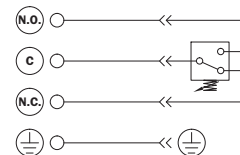



New Headquarters:

MP FILTRI S.p.A. Italy

Via 1° Maggio, n. 3
20060 Pessano con Bornago
(Milan) Italy
Tel. +39.02/95703.1
Fax +39.02/95741497-95740188
email: sales@mpfiltri.com
www.mpfiltri.com

GREAT BRITAIN

MP FILTRI U.K. Ltd.

Bourton Industrial Park
Bourton on the Water
Gloucestershire GL54 2HQ UK
Phone: +44.01451-822522
Fax: +44.01451-822282
email: sales@mpfiltri.co.uk
www.hydraulicparticlecounter.com
www.mpfiltri.com

GERMANY

MP FILTRI Germany GmbH

Hans - Wilhelmi - Straße 2
DE-66386 St. Ingbert
Phone: +49.(0)6894-95652-0
Fax: +49.(0)6894-95652-20
email: service@mpfiltri.de
www.mpfiltri.com

FRANCE

MP FILTRI FRANCE Sas

Parc d'activités des Chanteraines
8 rue du Commandant d'Estienne
d'Orves, Immeuble D3
92396 Villeneuve la Garenne - France
Phone: +33(0)1.40.86.47.00
Fax: +33(0)1.40.86.47.09
email: sales@mpfiltrifrance.com
www.mpfiltri.com

USA

MP FILTRI USA Inc.

2055 Quaker Pointe Drive
Quakertown, PA 18951
Phone: +1.215-529-1300
Fax: +1.215-529-1902
email: sales@mpfiltriusa.com
www.mpfiltriusa.com

CANADA

MP FILTRI CANADA Inc.

8831 Keele Street, Concord,
Ontario L4K 2N1, Canada
Phone: +1.905-303-1369
Fax: +1.905-303-7256
email: mail@mpfiltricanada.com
www.mpfiltricanada.com

RUSSIAN FEDERATION

ITALFILTRI

Yuryevskiy Pereulok 13 a, Building 1
111020 Moscow, Russia
Phone/Fax: +7(495)220-94-60
email: mpfiltrirussia@yahoo.com
www.mpfiltri.ru

CHINA

MP FILTRI (Shanghai) Co. Ltd.

1280 Lianxi Road, 8 Bld - 2 Floor
Shanghai, Pudong
201204 P.R. China
Phone: + 86.21-58919916
Fax: + 86.21-58919667
email: sales@mpfiltrishanghai.com
www.mpfiltri.com

INDIA

MP FILTRI INDIA Pvt. Ltd.

Plot-7F, Raj Pinnacle
Beside RMZ Centennial,
Brookefield Road, Whitefield,
Bangalore 560048 - India
Phone: +91-80-4147 7444/4146 1444
Fax: +91-80-41461888
email: sales@mpfiltri.co.in
www.mpfiltri.com